

Specification :

Part Name	Material Name
Body	FC200, Cast Iron
Cover	FC200, Cast Iron
Disc	FC200, Cast Iron
Body Seat	SUS304
Disc Seat	SUS304
End Standard	JIS 10K Flanged
Pressure Range	Up to 10Kg/cm ²
Temperature Range	0 to 200 °C
Fluid	Water, Oil, Gas, Steam

Testing Standard (Water) :

Standard	
Pressure Test	10 Kg/cm ²
Seat Test	12 Kg/cm ²
Shell Test	14 Kg/cm ²
Air Test	6 Kg/cm ²

Applicable Standard :

Standard	
Design Standard	JIS B2031, 10K
Face to face	JIS B2239, 10K
End Standard	JIS B2031, 10K
Pressure Rating	JIS B2003, 10K

Dimensions :

Size	mm									
	Inch	2"	2-1/2"	3"	4"	5"	6"	8"	10"	12"
	DN	50	65	80	100	125	150	200	250	300
L Face-to-face		200	240	260	300	350	400	500	500	540
H Height		130	140	150	160	190	210	250	310	340
D1 Flange PCD		120	140	150	175	210	240	290	355	400

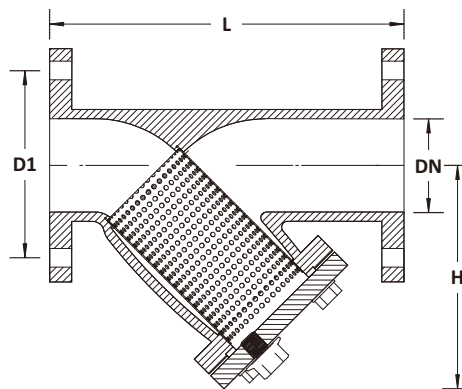

Specification :

Part Name	Material Name
Body	FC200, Cast Iron
Cover	FC200, Cast Iron
Screen	SUS304
Gasket	EPDM
Drain Port	FC200, Cast Iron
End Standard	JIS 10K Flanged
Pressure Range	Up to 10 Kg/cm ²
Temperature Range	0 to 120 °C
Fluid	Water, Oil, Gas

Testing Standard (Water) :

Standard	
Pressure	10 Kg/cm ²
Seat Test	12 Kg/cm ²
Shell Test	14 Kg/cm ²
Air Test	6 Kg/cm ²

Applicable Standard :

Pressure Rating	
Design	JIS B2220, 10K
Face to face	JIS B2220, 10K
End Standard	JIS B2220, 10K
Pressure Rating	JIS B2003

Dimensions :

Size	mm									
	Inch	2"	2-1/2"	3"	4"	5"	6"	8"	10"	12"
	DN	50	65	80	100	125	150	200	250	300
L Face-to-face		230	290	310	350	400	480	600	730	850
H Height		124	139	187	199	240	264	311	385	452
D1 Flange PCD		120	140	150	175	210	240	290	355	400